

- On-board network frontend supply
- Safety relevant topology¹⁾
- No breakthrough of input-output-input
- U_i lower/equal/higher than U_o
- U_i -range >1:4 continuous
- Active Transient protection filter¹⁾
- Active cross plugging protection
- VG 96916 T5, Option: MIL-Std 1275
- Dyn. and stat. short circuit proof
- EMC VG 95373 (Level. 2)
- Shock/vibration MIL Std 810

Special technology / Vehicles / Avionics / Off-shore



© registered trademark of company SYKO GmbH & Co. KG

Series BOS-MIL

Patented topologies

US Pat. no. 5.991.166 + 6.094.366
D Pat. no. 195 15 210 + 195 05 417
Pat. no DE 3804 074 C2 / EP 0402 367 B1

Main points:

Output:

- No load proof / short circuit proof
- Accuracy absolute $\pm 2\%$
- Regulation factor $\Sigma(U_i + I_o + T_a) \pm 2\%$
- Ripple <20 mV_{pp} (T 1:1/200MHz/50 Ω)
- Spikes <25 mV_{pp} (T 1:1/200MHz/50 Ω)
- Short circuit current <1,1I_{max}
- Response time ≤ 50 ms
- Dyn. regulation offset 40-90%: $\pm 3\%$
- Run-up delay <1,5s
- GND Output = GND Input
- Radio suppr. VG95373 LA01G level 2 NB
SA02G level 2 NB

Input:

- Fuse external by customer
- Cross plugging protection Cross diode
- Active Inrush current limitation (Patent AFI) <140A (24V-Version)
- Integral run-up current limitation¹⁾
- Dynamical current limitation dU/dt¹⁾
- Inhibit (Option) Sleep mode <0,5mA
- Disturbance protection VG 95373 LF01G; LF02G; LF03G; LF05G; RS03/SF03G; SA06S; SF01S; DIN EN61000-4-3 1kV/50 μ s/2 Ω
- Transient proof VG 96916 T5¹⁾ 50V 50ms / 70V 2ms / Option: 100V / 50ms

General:

- Current cascaded power stages¹⁾
- Radio suppression VG95373 Level 2 LA01G; SA02G; SA04G (consultation)
- Ambient temperature T_a -40°C / +70°C
- Option H: -40°C / +85°C (short term)
- Derating:
without forced ventilation 2%/°C >60°C
with forced ventilation 0,8%/°C >60°C
- Stable M8 screw connectors for input and output connection inside the housing
- Cable insertion with screw sealing
- Stable ground connector M6
- Weight approx. 11 kg
- Dimension 425 x 260 x 74 mm³
- Stable Aluminium housing with EMC barrier
- Protection level IP65 / colour RAL 6031 F9
- 8 flange mounting points for M6
- Shock / vibration MIL Std 810

U_i Battery V	P_o W stat. / dyn.	U_o V	I_o A	Model number 2)
9 - 16	600	12	50	BOS-MIL12.12.500
8 - 27 dyn.		15	40	BOS-MIL12.15.400
nom. 12		24	25	BOS-MIL12.24.250
		48	12,5	BOS-MIL12.48.125
9 - 34	600 / 800	12	65	BOS-MIL20.12.650
VG 96916 T5		15	52	BOS-MIL20.15.520
50V/50ms		24	32	BOS-MIL20.24.320
70V/2ms		48	16	BOS-MIL20.48.160
nom. 12/24				
16,8 - 34	800 / 1000	12	80	BOS-MIL24.12.800
10V dyn.		15	65	BOS-MIL24.15.650
VG 96916 T5		24	40	BOS-MIL24.24.400
50V/50ms		48	20	BOS-MIL24.48.200
70V/2ms				
nom. 24				
Modification costs for possible changes above values:				on request

1) The points are given by the following patents:

Regenerator Topology: US Pat. No. 5.991.166 + 6.094.366 / D Pat. No. 195 15 210 + 195 05 417
Active transient protection: Pat. No. DE 3804 074 C2 / EP 0402 367 B1

2) Option: Battery charging or High-Cap charging with charging end voltage as BOS-LDG or intelligent battery charging = f(TBat) as BOS-BLG
Modification costs occur

3) Optionally the internal power card can be offered without housing for customer sided integration on an existing heat sink.

For the **BOS-MIL** series the patented Regenerator topology and the patented active and cascaded transient protection filter were used to generate an on-board precision network from the vehicle's unfiltered transient carrying battery network.

Wide input voltage range for one or more nominal battery levels with +40%/-25% and dyn. -30/-40% short term is realised. Optionally an active low-loss cross plugging protection can be implemented, which results continuous operation in the case of input voltage drops down to zero volt in combination with active hold-up time of >50ms (slip ring interruptions).

The Regenerator topology works safety relevant because the punch-through of input to output side with integrated fuse is prevented. The input voltage can be lower, equal or higher than the non isolated and regulated or adaptable as well as short circuit proof output voltage. (Regeneration of on-board network).

The patented topology's current cascading realises an accurate current splitting to each single power stages and unneeded stress for the components is prevented. High chopping currents are processed by ceramic capacitors and high quality electrolytic capacitors are just used for the continuous support. For the input and output the VG 95373 level 2 limits are realised by the mechanical construction details and EMC efforts.

Please hand over your customised demands when the function of CAP-charging or lead battery charging to charging end voltage or optionally the modification of an intelligent temperature regulated battery charging must be realised.

By the use of an optional Sleep-mode-Inhibit function the converter is inactive and the current consumption is <0,5mA. When a voltage signal is connected to this input (4,5–36 V plus transients) the converter is activated by a constant signal current of 2mA.

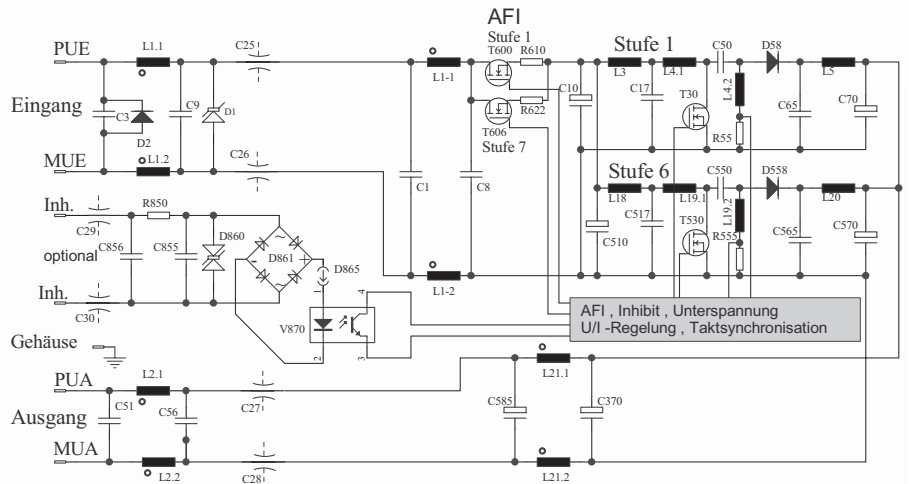

© registered trademark of company SYKO GmbH & Co. KG

Measurement of radio interference
Input

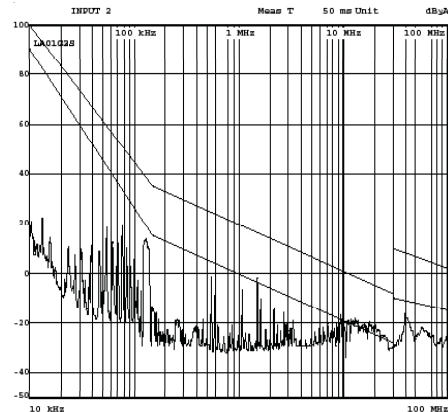

Output

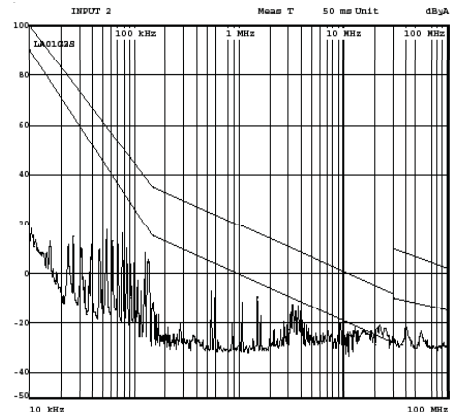

Mechanic

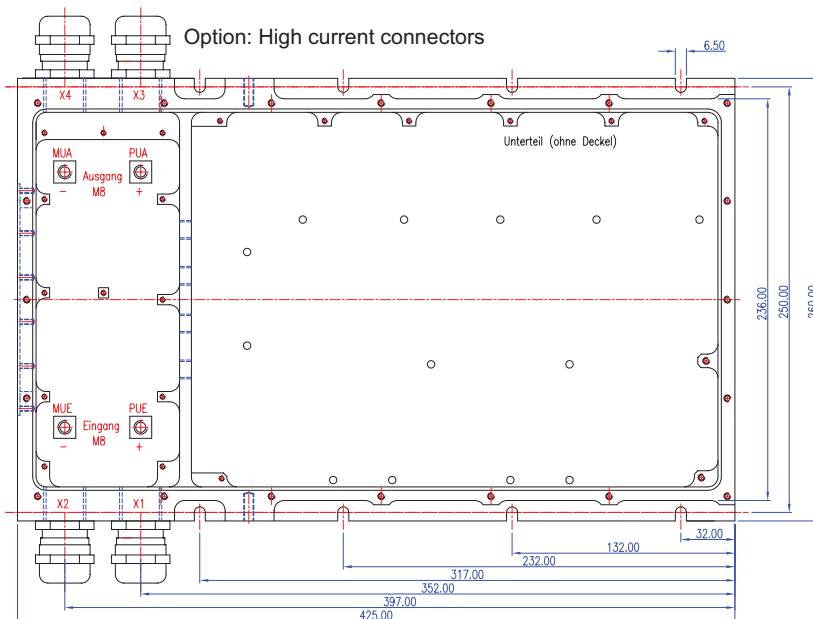
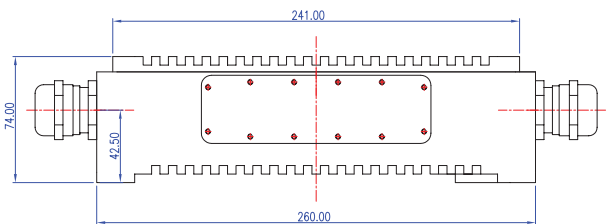
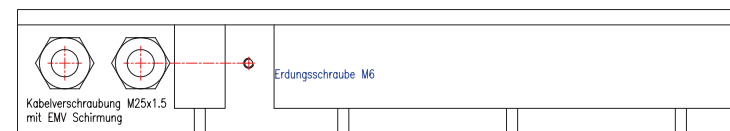

Derating-curve

